

USN

--	--	--	--	--	--	--	--	--	--

06MAT31

Third Semester B.E. Degree Examination, June/July 2011
Engineering Mathematics

Time: 3 hrs.

Max. Marks:100

**Note: Answer FIVE full questions selecting
at least TWO questions from each part.**

PART - A

- 1 a. Find a Fourier series to represent $f(x) = x - x^2$ from $x = -\Pi$ to $x = \Pi$ and deduce that $\frac{\Pi^2}{12} = \frac{1}{1^2} - \frac{1}{2^2} + \frac{1}{3^2} - \frac{1}{4^2} + \dots$ (07 Marks)
- b. If $f(x) = \begin{cases} x & 0 < x < \frac{\Pi}{2} \\ \Pi - x & \frac{\Pi}{2} < x < \Pi \end{cases}$
show that i) $f(x) = \frac{4}{\Pi} \left[\sin x - \frac{1}{3^2} \sin 3x + \frac{1}{5^2} \sin 5x - \dots \right]$
ii) $f(x) = \frac{\Pi}{4} - \frac{2}{\Pi} \left[\frac{1}{1^2} \cos 2x + \frac{1}{3^2} \cos 6x + \frac{1}{5^2} \cos 10x + \dots \right]$ (07 Marks)
- c. Obtain the Fourier series neglecting the terms higher than first harmonic.

x	0	1	2	3	4	5
y	9	18	24	28	26	20

(06 Marks)

- 2 a. Find the Fourier transform of the function $f(x) = \begin{cases} x, & |x| \leq \infty \\ 0, & |x| > \infty \end{cases}$ where ' ∞ ' is a positive constant. (06 Marks)
- b. Solve the integral equation $\int_0^{\infty} f(\theta) \cos \theta d\theta = \begin{cases} 1 - \infty & 0 \leq \infty \leq 1 \\ 0 & \infty > 0 \end{cases}$
Hence evaluate $\int_0^{\infty} \frac{\sin^2 t}{t^2} dt$ (08 Marks)
- c. Find the finite Fourier sine transform of $f(x) = 2x$ in $0 \leq x \leq 4$. (06 Marks)
- 3 a. Form the Partial Differential equation by eliminating the arbitrary function from the equation $F(xy + z^2, x + y + z) = 0$ (06 Marks)
- b. Solve: $xp - yq = y^2 - x^2$. (07 Marks)
- c. Solve $py^3 + qx^2 = 0$ by the method of separation of variable. (07 Marks)
- 4 a. Derive one dimensional heat equation. (07 Marks)
- b. Find the deflections of a vibrating string of unit length fixed ends with initial velocity zero and initial deflections $f(x) = k(\sin x - \sin 2x)$. (06 Marks)
- c. Solve $\frac{\partial^2 u}{\partial x^2} + \frac{\partial^2 u}{\partial y^2} = 0$ subject to the conditions
 $u(0, y) = u(l, y) = u(x, 0) = 0$ and $u(x, a) = \sin \frac{n\Pi x}{1}$. (07 Marks)

PART - B

- 5 a. Find the real root of the equation $xe^x = 2$ correct to three decimal places using Newton-Raphson method. (07 Marks)
- b. Employ Gauss-Siedel iteration method to solve:
 $20x + y - 2z = 17$
 $2x - 3y + 20z = 25$
 $3x + 20y - z = 18$
 Carryout 3 iterations. (07 Marks)
- c. Using Power method find the dominant eigen value and the corresponding eigen vector of the matrix $A = \begin{bmatrix} 4 & 1 & -1 \\ 2 & 3 & -1 \\ -2 & 1 & 5 \end{bmatrix}$ (06 Marks)
- 6 a. Using suitable interpolation formula, find the number of students who obtained marks between 40 and 45. (07 Marks)

Marks	30-40	40-50	50-60	60-70	70-80
No. of students	31	42	51	35	31

- b. Using divided difference formula to find $f(x)$ given data hence find $f(4)$. (07 Marks)

x	0	2	3	6
f(x)	-4	2	14	158

- c. Using Simpson's $\frac{1}{3}$ rd Rule to find $\int_0^{0.6} e^{-x^2} dx$ by taking seven ordinates. (06 Marks)

- 7 a. State and prove Euler's equation. (07 Marks)
- b. Solve the variation problem $\sigma \int_0^1 (y^2 + x^2 y^1) dx = 0, y(0) = 0, y(1) = 1$. (06 Marks)
- c. Find the path in which a particle in the absence of friction will slide from one point to another in the shortest time under the action of gravity. (07 Marks)

- 8 a. Find the z-transform of $\cosh n \theta$ and $\sinh n \theta$. (06 Marks)
- b. Find the inverse z-transform of $\frac{z^3 - 20z}{(z-3)^2(z-4)}$. (07 Marks)
- c. Solve: $y_{n+2} + 6y_{n+1} + 9y_n = 2^n$ with $y_0 = y_1 = 0$ using z-transform. (07 Marks)

USN

--	--	--	--	--	--	--	--	--	--

MATDIP301

Third Semester B.E. Degree Examination, June/July 2011
Advanced Mathematics – I

Time: 3 hrs.

Max. Marks:100

Note: Answer any FIVE full questions.

- 1 a. Express $\frac{(1+i)(2+i)}{3+i}$ in the form $a + ib$. (05 Marks)
- b. Put the complex number $1 - i\sqrt{3}$ in polar form. (05 Marks)
- c. Simplify $\frac{(\cos 6\theta - i \sin 6\theta)^3 (\cos 2\theta + i \sin 2\theta)^7}{(\cos 4\theta - i \sin 4\theta)^3}$. (05 Marks)
- d. Find the cube roots of $1 - i$. (05 Marks)
- 2 a. Find the n^{th} derivative of $e^{ax} \sin (bx + c)$. (06 Marks)
- b. Find the n^{th} derivative of $\frac{x+3}{(x-1)(x+2)}$. (07 Marks)
- c. If $y = e^{m \sin^{-1} x}$ then prove that $(1-x^2)y_{n+2} - (2n+1)xy_{n+1} - (n^2+m^2)y_n = 0$. (07 Marks)
- 3 a. With usual notation, prove that $\tan \phi = r \frac{d\theta}{dr}$. (06 Marks)
- b. Show that the curves $r = a(1 + \cos \theta)$ and $r = a(1 - \cos \theta)$ intersect orthogonally. (07 Marks)
- c. Expand $\log(1+x)$ in ascending powers of x as far as the terms containing x^4 . (07 Marks)
- 4 a. If $u = e^{ax+by} f(ax-by)$, prove that $b \frac{\partial u}{\partial x} + a \frac{\partial u}{\partial y} = 2abu$. (06 Marks)
- b. If u is a homogenous function of degree 'n' then prove that $x \frac{\partial u}{\partial x} + y \frac{\partial u}{\partial y} = nu$. (07 Marks)
- c. If $u = x^2 + y^2 + z^2$, $v = xy + yz + zx$, $w = x + y + z$. find $J \left(\begin{matrix} u, v, w \\ x, y, z \end{matrix} \right)$. (07 Marks)
- 5 a. Obtain the reduction formula for $\int \cos^n x \, dx$ where 'n' is a positive integer and hence evaluate $\int \cos^5 x \, dx$. (06 Marks)
- b. Evaluate $\int_0^1 x^6 \sqrt{1-x^2} \, dx$. (07 Marks)
- c. Evaluate $\int_{-c}^c \int_{-b}^b \int_{-a}^a (x^2 + y^2 + z^2) dz \, dy \, dx$. (07 Marks)

6 a. Evaluate $\int_0^{\infty} x^{\frac{3}{2}} e^{-4x} dx$. (06 Marks)

b. Prove that $\beta(m, n) = \frac{\Gamma(m) \cdot \Gamma(n)}{\Gamma(m+n)}$. (07 Marks)

c. Prove that $\int_0^{\frac{\pi}{2}} \sqrt{\sin \theta} d\theta \times \int_0^{\frac{\pi}{2}} \frac{1}{\sqrt{\sin \theta}} d\theta = \pi$. (07 Marks)

7 a. Solve $\frac{dy}{dx} = e^{3x-2y} + x^2 e^{-2y}$. (06 Marks)

b. Solve $\frac{dy}{dx} = \cos(x+y+1)$. (07 Marks)

c. Solve $x^2 y dx - (x^3 + y^3) dy = 0$. (07 Marks)

8 a. Solve $\frac{d^3 y}{dx^3} + 6 \frac{d^2 y}{dx^2} + 11 \frac{dy}{dx} + 6y = 0$. (06 Marks)

b. Solve $(D^2 + 3D + 2)y = x^2 + 3x + 1$. (07 Marks)

c. Solve $(D^2 + 4)y = \sin^2 2x$. (07 Marks)

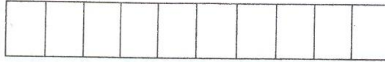

Third Semester B.E. Degree Examination, June/July 2011
Electronic Circuits

Time: 3 hrs.

Max. Marks:100

Note: Answer any FIVE full questions selecting at least TWO from each part.

PART – A

1.
 - a. Illustrate the working of a double ended biased clipper with the help of circuit diagram, transfer characteristics and input output waveform. (08 Marks)
 - b. Explain the working principle of VARACTOR. (06 Marks)
 - c. Design a lossless capacitor based ac power line LED indicator operating on 120V – 230V, 50Hz variable ac mains. Determine the average LED current, assuming that the LED indicator is connected on the primary side of the transformer and peak LED current not exceeding 15 mA. Assume nominal value of $V_D = 2V$. (06 Marks)
2.
 - a. In the Fig.Q2(a), what is the lowest frequency at which good by pass exists? If the lowest frequency is 1 KHz and the highest frequency is 10 KHz, what value of C is required for effective bypass? (04 Marks)

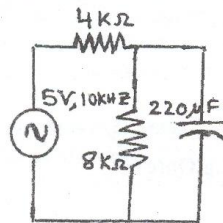

Fig.Q2(a)

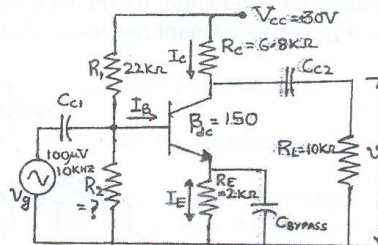

Fig.Q2(b)

- b. Using the condition for stiff voltage divider bias for the BJT amplifier circuit shown in Fig.Q2(b), determine the terminal currents I_B , I_C and I_E , the terminal voltage V_{CE} , the saturation current $I_{C(SAT)}$ and the cut-off voltage $V_{CE(cut\ off)}$. Draw the DC load line and mark the Q point on the I_C versus V_{CE} characteristics plot. (10 Marks)
 - c. Write a brief note on distortion in small signal operation of a transistor (BJT) based amplifier and how it can be reduced. (06 Marks)
3.
 - a. Calculate the output voltage v_{01} and v_{02} of a two stage BJT amplifier circuit shown in Fig.Q3(a), if the bypass capacitor $C_{bypass1}$ for the first stage has snapped (open). Given $\beta = 150$, $V_g = 4\text{ mV p-p}$, 20 KHz, draw the equivalent π -model for the two stage amplifier. (10 Marks)

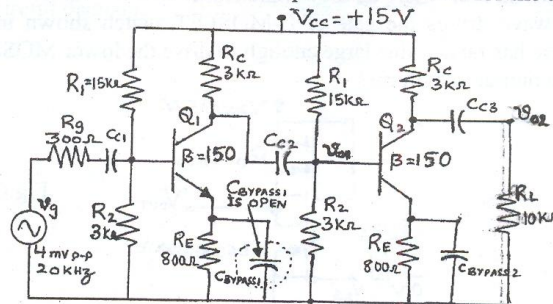

Fig.Q3(a)

(10 Marks)

- 3 b. Prove that the voltage gain for a common collector amplifier is approximately unity. (04 Marks)
- c. What is the output voltage V_{OUT} , the load current I_L , the emitter current I_{E2} , collector to emitter voltage V_{CE2} and the currents I_{R1} and I_{R2} in the circuit shown in Fig.Q3(c)? (06 Marks)

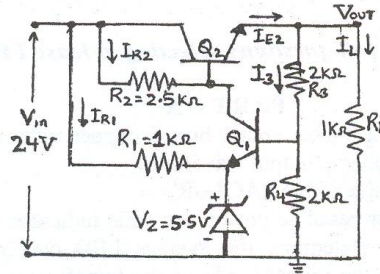

Fig.Q3(c)

- 4 a. List the important characteristics of class - A, B, AB and C amplifiers in terms of conduction angle, operating region, application and efficiency. (08 Marks)
- b. With the aid of a circuit diagram, discuss the working of class-B push-pull power amplifier along with its advantages and disadvantages. (06 Marks)
- c. Calculate the bandwidth, maximum dissipated power in the transistor and maximum output power for the tuned amplifier circuit shown in Fig.Q4(c). (06 Marks)

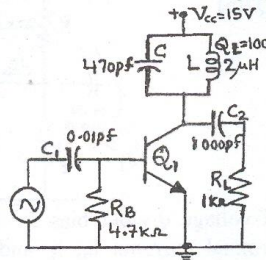

Fig.Q4(c)

PART - B

- 5 a. Draw and explain the working of D-MOSFET with the help of drain curve and transconductance curve. When a +ve voltage is applied to the gate of a P-channel D-MOSFET, is the current flow depleted or enhanced. (09 Marks)
- b. What are the major differences between D-MOSFET and E-MOSFET? What type of voltage is necessary at the gate of a P-channel E-MOSFET to cause a current flow? What are the induced carriers and where do they come from? (07 Marks)
- c. A square wave drives the gate of E-MOSFET switch shown in Fig.Q5(c). If the 10KHZ square wave has peak value large enough to drive the lower MOSFET into the ohmic region, what is the output waveform? (04 Marks)

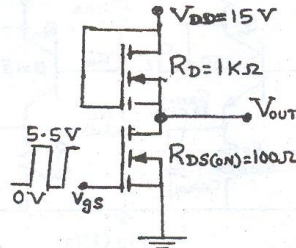

Fig.Q5(c)

- 6 a. Draw and explain the frequency response curve of an ac amplifier and the significance of cut-off frequency. Write the expression for voltage gain beyond mid band. (07 Marks)
- b. Determine the output current, current gain and load power for the LM741 OPAMP circuit shown in Fig.Q6(b). Also determine the closed-loop bandwidth for $f_{2(o)} = 120\text{Hz}$ and $(1 + A_{vol}B) = 5000$. (04 Marks)

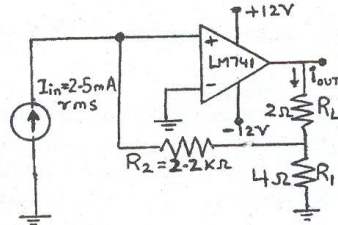

Fig.Q6(b)

- c. Draw the equivalent circuit of a trans-resistance amplifier. List down its important characteristics. Derive an expression for voltage gain of OPAMP based voltage amplifier. (09 Marks)
- 7 a. With the help of a circuit diagram, waveforms, hysteresis plot and relevant formulas, explain the working of OPAMP based Schmitt trigger. (08 Marks)
- b. With the aid of circuit pin diagram and waveforms, explain the operation of 555 timer as an ASTABLE multi vibrator to get 50% duty cycle. (07 Marks)
- c. Explain the working of RAMP generator and the importance of current mirror. (05 Marks)
- 8 a. Define locking range and capture range in PLL and its importance. Name any two applications where PLL's are used. (05 Marks)
- b. An LM317 adjustable regulator shown in Fig.Q8(b) is used for obtaining regulated DC output voltage. Calculate the approximate output voltage and the maximum, minimum efficiency, if the input voltage V_{in} varies between 30V and 48V. What would be the output voltage if R_2 value is doubled? Assume $V_{REF} = 1.25\text{V}$. (04 Marks)

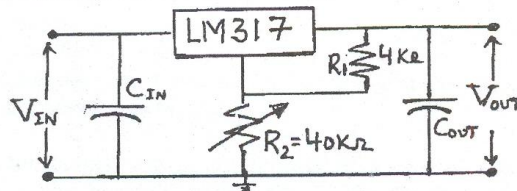

Fig.Q8(b)

- c. Explain the significance of line and load regulation. (04 Marks)
- d. With the aid of a circuit diagram, explain the working of step-up Boost regulator. (07 Marks)

USN

--	--	--	--	--	--	--	--	--	--	--	--

06CS33

Third Semester B.E. Degree Examination, June/July 2011

Logic Design

Time: 3 hrs.

Max. Marks:100

Note: Answer any FIVE full questions selecting at least TWO questions from each part.

PART – A

1. a. Explain the significance of DeMorgan's theorem. (04 Marks)
 b. Simplify the following function using k-map and design it by using NAND gates (use only four gates):
 $f = w'xz + w'yz + x'yz' + wxy'z$; $d = wyz$ (08 Marks)
 c. Define prime implicant and essential prime implicant. Find prime implicant and essential prime implicant for the following function using Quine-Mcclusky method :
 $f(a, b, c, d) = \sum m(0, 2, 3, 6, 7, 8, 10, 12, 13)$ (08 Marks)
2. a. What is multiplexer? Design 4 : 1 multiplexer and implement using gates. (04 Marks)
 b. Implement the following function using decoder :
 $F_1(A, B, C) = \sum m(0, 4, 6)$; $F_2(A, B, C) = \sum m(0, 5)$; $F_3(A, B, C) = \sum m(1, 2, 3, 7)$. (08 Marks)
 c. Implement the following function using PLA :
 $X = A'B'C + AB'C' + B'C$; $Y = A'B'C + AB'C'$; $Z = B'C$. (08 Marks)
3. a. i) Convert the following decimal numbers into their binary equivalent :
 A) 10 B) 15 C) 2 D) 4
 ii) Represent all the above numbers as :
 A) Unsigned binary numbers B) Sign magnitude numbers
 C) 1's complement of each number D) 2's complement of each number
 iii) Illustrate the following operators:
 A) +67, -98 (8 bit binary addition) B) +16, -38 (8 bit binary subtraction) (08 Marks)
 b. Explain the working principle of 2-bit fast adder with neat diagram. (08 Marks)
 c. Write HDL design of full adder. (04 Marks)
4. a. Draw the state transition of the circuit shown in Fig.Q4(a) : (06 Marks)

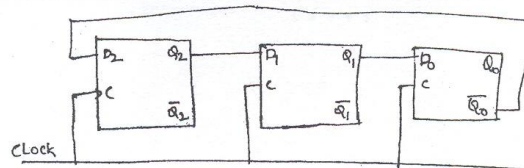

Fig.Q4(a)

- b. With the help of neat diagram explain the working of Master-Slave JK Flip Flop. Mention its advantages. (10 Marks)
- c. Write HDL design of D-Flip Flop. (04 Marks)

Important Note : 1. On completing your answers, compulsorily draw diagonal cross lines on the remaining blank pages.
 2. Any revealing of identification, appeal to evaluator and/or equations written eg, 42+8 = 50, will be treated as malpractice.

PART – B

- 5 a. Design a mod-6 synchronous upcounter using JK-Flip-Flop. (08 Marks)
 b. Define shift register? Explain 4-bit switched tail counter with neat diagram. (08 Marks)
 c. Design 3-bit ripple counter. (04 Marks)
- 6 a. Design a sequence detector that receives binary data stream at its input X and signals when a combination "1011" arrives at the input by masking its output Y high which otherwise remains low. Consider data is coming from left, that is, the first bit to be identified is 1, second is 1, third is 0 from input sequence. (06 Marks)
 b. Differentiate between Mealy machine and Moore machines. (04 Marks)
 c. Reduce state diagram shown in Fig.Q6(c) (Moore model) using following methods:
 i) Row elimination method ii) Implication table method (10 Marks)

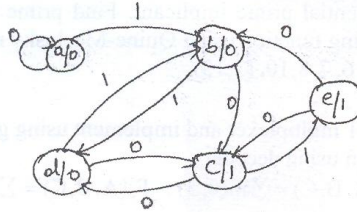

Fig.Q6(c)

- 7 a. Explain A/D converter by using counter method. (08 Marks)
 b. Explain the following with neat diagram :
 i) TTL NOR ii) 2-input CMOS NOR
 iii) TTL NAND iv) 2-input CMOS NAND (12 Marks)
- 8 a. With the help of the circuit diagram explain the working of a 4-bit D/A converter. (08 Marks)
 b. Write short notes on:
 i) Magnitude comparator
 ii) CMOS characteristics
 iii) Racing
 iv) Totem pole. (12 Marks)

--	--	--	--	--	--	--	--	--	--

Third Semester B.E. Degree Examination, June/July 2011
Discrete Mathematical Structures

Time: 3 hrs.

Max. Marks:100

**Note: Answer FIVE full questions, selecting
at least TWO questions from each part..**

PART - A

- 1 a. For any three sets A, B and C, prove the following :
 $A - (B \cup C) = (A - C) - (B - C) = (A - C) - B.$ (08 Marks)
- b. A professor has two dozen introductory test books on computer science. He is concerned about their coverage of the topics (A) compilers, (B) data structures and (C) operating systems. Following data are the number of books which contain material on these topics.
 $|A| = 8, |B| = 13, |C| = 13, |A \cap B| = 5, |A \cap C| = 3, |B \cap C| = 6$ and $|A \cap B \cap C| = 2.$ Determine :
 i) The number of test books which include material on exactly one of these topics.
 ii) The number of text books which do not deal with any of the topics. (06 Marks)
- c. An integer is selected at random from 3 through 17 inclusive. If A is the event that a number divisible by 3 is chosen and B is the event that the number exceeds 10, determine $\Pr(A), \Pr(B), \Pr(A \cap B)$ and $\Pr(A \cup B).$ How is $\Pr(A \cup B)$ related to $\Pr(A), \Pr(B)$ and $\Pr(A \cap B)?$ (06 Marks)
- 2 a. Establish the following :
 P
 $p \rightarrow q$
 $s \vee r$
 $r \rightarrow \neg q$
 $\therefore s \vee t.$ (06 Marks)
- b. Show that each of the following arguments is invalid by providing a counter example – that is an assignment of truth values for the given primitive statements such that all premises are true while the conclusion is false.
 i) $p \wedge \neg q$
 $\frac{p \rightarrow (q \rightarrow r)}{\therefore \neg r}$
 ii) $P \leftrightarrow q$
 $q \rightarrow r$
 $r \vee \neg s$
 $\frac{\neg s \rightarrow q}{\therefore s.}$ (08 Marks)
- c. Consider each of the following arguments. If the argument is valid, identify the rule inference which establishes its validity. If not, indicate whether the error is due to an attempt to argue by converse or by the inverse.
 i) If Gopal's computer program is correct, then he will be able to complete his computer science assignment in at most three hours
 ii) It takes Gopal over three hours to complete his computer science assignment. Therefore Gopal's computer program is not correct.
 iii) If interest rates fall, then the stock market will rise. Interest rates are not falling. Therefore the stock market will not rise. (06 Marks)

- 3 a. For the following statement. State the converse, inverse and contrapositive. Determine the truth value of the given statement and the truth values of its converse, inverse and contrapositive. The universe consists of all integers.
If m divides n and n divides p , then m divides p . (06 Marks)
- b. Establish the validity of the following argument
- $$\begin{array}{l} (x) [p(x) \vee q(x)] \\ (x) [(\neg p(x) \wedge q(x) \rightarrow r(x))] \\ \therefore (x) [\neg r(x) \rightarrow p(x)] \end{array}$$
- (08 Marks)
- c. Let n be an integer. Prove that n is odd if and only if $\neg n + 8$ is odd. (06 Marks)
- 4 a. Prove the following using the principle of mathematical induction
- i) $1^2 + 3^2 + 5^2 + \dots + (2n-1)^2 = \frac{n(2n-1)(2n+1)}{3}$
- ii) $1 \times 3 + 2 \times 4 + 3 \times 5 + \dots + n(n+2) = \frac{n(n+1)(2n+7)}{6}$. (08 Marks)
- b. Prove that any positive integer greater than or equal to 14 can be expressed as sum of 3s and / or 8s. (06 Marks)
- c. Fibonacci members are defined recursively as follows
 $F_0 = 0, F_1 = 1$ and $F_n = F_{n-1} + F_{n-2}$ for $n \in \mathbb{Z}^+$ with $n \geq 2$. Show that $\sum_{i=0}^n F_i^2 = F_n \times F_{n+1}$ for all $n \in \mathbb{Z}^+$, where \mathbb{Z}^+ denotes the set of all positive integers. (06 Marks)

PART - B

- 5 a. Consider two functions $f: A \rightarrow B$ and $g: B \rightarrow C$. Prove that if $g \circ f: A \rightarrow C$ is one-one, then f is one-one and if $g \circ f: A \rightarrow C$ is onto, then g is onto. (07 Marks)
- b. Let $f, g, h: \mathbb{Z} \rightarrow \mathbb{Z}$ be defined as $f(x) = x - 1, g(x) = 2x$ and $h(x) = \begin{cases} 7 & \text{if } x \text{ is even} \\ 4 & \text{if } x \text{ is odd} \end{cases}$
- Determine:
- $f \circ g$
 - $g \circ f$
 - $g \circ h$
 - $h \circ g$
 - $f \circ (g \circ h)$
 - $(f \circ g) \circ h$.
- (06 Marks)
- c. Show that if any 14 integers are selected from the set $S = \{1, 2, 3, \dots, 25\}$, there are at least two integers whose sum is 26. (07 Marks)

- 6 a. Let A be a finite set which consists of n elements. Determine the number of relations on A which are i) reflexive ii) symmetric iii) antisymmetric. (08 Marks)
- b. Let $A = \{a, b, c, d, e, f, g\}$ and consider the partition $P = \{\{a, c, d\}, \{b\}, \{e, g\}, \{f\}\}$. Determine the corresponding equivalence relation R . (03 Marks)
- c. For the posets whose Hasse diagrams are given in Fig.Q6(c)(i) and (ii), find maximal elements and minimal elements (if they exist). (04 Marks)

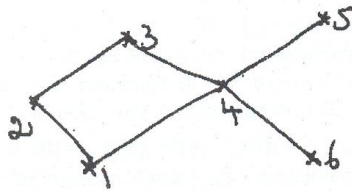

Fig. Q6(c)(i)

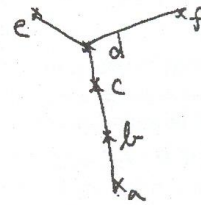

Fig. Q6(c)(ii)

- d. Consider the poset (A, \leq) where $A = \{a, b, c, d, e, f, g, h\}$ and \leq is given by the following Hasse diagram, shown in Fig.Q6(d).

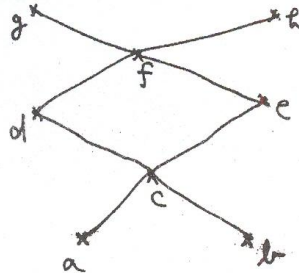

Fig. Q6(d)

Consider the subset $B = \{c, d, e\}$. If upper bounds and lower bounds of B exist find them. If they exist, determine the least upper bound (lub) and greatest lower bound (glb). (05 Marks)

- 7 a. Let \mathbb{R}^* denote the set of all non zero real numbers and let $S = \mathbb{R}^* \times \mathbb{R}$. Define an operation \circ on S as $(u, v) \circ (x, y) = (ux, vx + y)$. Prove that (S, \circ) is a nonabelian group. (07 Marks)
- b. State and prove Lagrange's theorem. (07 Marks)
- c. For a group G , prove that the function $f: G \rightarrow G$ defined as $f(a) = a^{-1}$ is an isomorphism if and only if G is abelian. (06 Marks)
- 8 a. In a group code, prove that the minimum distance between distinct code words is the minimum of the weights of the non zero elements of the code. (06 Marks)
- b. Let $(R, +, *)$ be a ring such that $a * a = a$ for all $a \in R$. Prove the following :
 i) $a + a = 0$ for all $a \in R$, where 0 denotes the identity element of $(R, +)$
 ii) $*$ is commutative. (08 Marks)
- c. Prove that a field is an integral domain. Give an example of an integral domain which is not a field. (06 Marks)

USN

--	--	--	--	--	--	--	--	--	--

06CS35

Third Semester B.E. Degree Examination, June/July 2011
Data Structure with C

Time: 3 hrs.

Max. Marks:100

Note: 1. Answer any FIVE full questions.
2. Answer at least One question from Part – A.

PART – A

- 1 a. What are Lvalue and Rvalue? Explain with example. (06 Marks)
- b. What is pointer to an array and array of pointers? Explain with example. (08 Marks)
- c. Explain dangling pointers and memory leakage with example. (06 Marks)
- 2 a. Explain string token function. Write a program to parse a simple algebraic expression SUM = SUM + 10 ; using the delimiters white space and semicolon. (10 Marks)
- b. How structure can be parsed to a function through pointers? Explain with example. (05 Marks)
- c. Explain the functions to access FILE randomly in file handling process. (05 Marks)

PART – B

- 3 a. Write a function to convert a valid infix expression to prefix expression. Demonstrate the same function with example. (12 Marks)
- b. Write a function i) INSERTION ; ii) DELETION with respect to circular queue. (08 Marks)
- 4 a. What is a recursion? Write a recursive function to
 - i) to find GCD of two number.
 - ii) to find factorial of a number.
 - iii) to reverse positive integer number. (12 Marks)
- b. Write a C program to implement a STACK using linked list. (08 Marks)
- 5 a. Write a function
 - i) to reverse the direction of singly linked list.
 - ii) to count number of nodes in a singly linked list.
 - iii) to create ordered linked list. (12 Marks)
- b. Enlist the advantages and disadvantages of DLL over SLL. Doubly Linked List (DLL), Single Linked List (SLL). (08 Marks)
- 6 a. Write a function to insert and delete a node, in Doubly Linked List, with respect to given position. (10 Marks)
- b. What is dynamic memory allocation? Write a function to delete a node from a circular linked list. Proper error message should be displayed. (10 Marks)
- 7 a. What is a TREE? Explain how TREE can be represented using structure. (05 Marks)
- b. Write a function to create binary search TREE. (05 Marks)
- c. Define post order and pre order traversal of Tree. Given the post order and pre order traversal, construct a single binary Tree.
 POST ORDER : J H D E B I F G C A
 IN ORDER : D J H B E A F I C G. (10 Marks)
- 8 Write a short notes on : a. Structure and union ; b. FILE handling ; c. Circular LINKED LIST ; d. BINARY TREE. (20 Marks)

Important Note : 1. On completing your answers, compulsorily draw diagonal cross lines on the remaining blank pages.
 2. Any revealing of identification, appeal to evaluator and/or equations written eg, 42+8 = 50, will be treated as malpractice.

USN

--	--	--	--	--	--	--	--	--	--

06CS36

Third Semester B.E. Degree Examination, June/July 2011
UNIX and Shell Programming

Time: 3 hrs.

Max. Marks:100

Note: Answer any FIVE full questions.

1.
 - a. With neat diagram, explain the architecture of Unix Operating System. (06 Marks)
 - b. With the help of a diagram, explain the parent-child relationship. Explain the Unix file system. (06 Marks)
 - c. Explain the following with examples :
 - i) Absolute and Relative pathnames
 - ii) Internal and External commands. (08 Marks)
2.
 - a. Give the significance of seven attributes of the `ls - l` command. (07 Marks)
 - b. What is file permissions? Explain how to change basic file permission with an example. (07 Marks)
 - c. Explain the different modes in which a Vi editor works. (06 Marks)
3.
 - a. Explain the three standard files with respect to Unix operating system. (06 Marks)
 - b. Explain the mechanism of process creation. (06 Marks)
 - c. Explain the following commands with an example :
 - i) Running jobs in Background (`&` and `nohup`)
 - ii) Execute later (`at` and `batch`). (08 Marks)
4.
 - a. What are Environment variables? Explain different environment variables available in Unix operating system. (06 Marks)
 - b. What are the differences between Softlink and Hardlink? Give examples. (06 Marks)
 - c. Write short notes on Find and Sort commands. (08 Marks)
5.
 - a. Explain "grep" command with all options. (08 Marks)
 - b. Explain BRE (Basic Regular Expression) character subset used for constructing regular expressions. (05 Marks)
 - c. Give the syntax of a Sed command line and briefly explain each component of this line. (07 Marks)
6.
 - a. Explain the use of test and [] to evaluate an expression in shell. (06 Marks)
 - b. What is shell programming? Write a shell program to create a menu which displays the list of files, current date, process status and current users of the system. (08 Marks)
 - c. Explain the shell features of "while" and "for" with syntax. (06 Marks)
7.
 - a. What is AWK? Explain any three built in functions in AWK. (07 Marks)
 - b. Write an AWK sequence to find HRA, DA and Netpay of an employee, where DA is 50% of basic, HRA is 12% of basic and the netpay is the sum of HRA, DA and Basic pay. (07 Marks)
 - c. Explain the list and arrays in PERL. (06 Marks)
8.
 - a. Explain string handling function in PERL and also write a program to find the number of characters, words as well as to print the reverse of a given sentence. (08 Marks)
 - b. What do the Chop() and Split () functions do? Explain. (06 Marks)
 - c. Explain file handling in PERL. (06 Marks)

Important Note : 1. On completing your answers, compulsorily draw diagonal cross lines on the remaining blank pages.
 2. Any revealing of identification, appeal to evaluator and /or equations written eg, 42+8 = 50, will be treated as malpractice.