

# GBCS SCHEME

USN

--	--	--	--	--	--	--	--	--	--

15ME81

## Eighth Semester B.E. Degree Examination, July/August 2021 Operations Research

Time: 3 hrs.

Max. Marks: 80

*Note: Answer any FIVE full questions.*

- 1**
- a. Define Operation Research. Discuss the scope of Operation Research. (06 Marks)
- b. A firm manufactures 3 products A, B and C. Time to manufacture product A is twice for B and thrice for C and if the entire labour is engaged in making product A, 1600 units of this product can be produced. These products are to be produced in the ratio 3:4:5. There is demand for at least 300, 250 and 200 units of products A, B and C and the profit earned per unit if Rs.90, Rs.40 and Rs.30 respectively. Formulate the problem as a LPP. (10 Marks)
- 2**
- a. Discuss the assumptions made in LPP. (06 Marks)
- b. Solve the following LPP graphically:  
Maximize  $Z = 2x_1 + 3x_2$   
Subject to constraints  $x_1 + x_2 \leq 30$ ,  
 $x_2 \geq 3$ ,  
 $x_2 \leq 12$ ,  
 $x_1 - x_2 \geq 0$ ,  
 $0 \leq x_1 \leq 20$  (10 Marks)
- 3**
- a. Explain the significance of following variables in LPP:  
i) Slack variable  
ii) Surplus variable  
iii) Artificial variable. (06 Marks)
- b. Solve by simplex method the following LPP:  
Minimize  $Z = x_1 - 3x_2 + 3x_3$   
Subject to constraints  $3x_1 - x_2 + 2x_3 \leq 7$ ,  
 $2x_1 + 4x_2 \geq -12$ ,  
 $-4x_1 + 3x_2 + 8x_3 \leq 10$ ,  
 $x_1, x_2, x_3 \geq 0$  (10 Marks)
- 4**
- a. What is Pseudo-optimal solution? (06 Marks)
- b. Solve the following LPP by Big-M method  
Maximize  $Z = 2x_1 + 3x_2 + 4x_3$   
Subject to constraint  $3x_1 + x_2 + 4x_3 \leq 600$ ,  
 $2x_1 + 4x_2 + 2x_3 \geq 480$ ,  
 $2x_1 + 3x_2 + 3x_3 = 540$ ,  
 $x_1, x_2, x_3 \geq 0$  (10 Marks)

Important Note : 1. On completing your answers, compulsorily draw diagonal cross lines on the remaining blank pages.  
2. Any revealing of identification, appeal to evaluator and /or equations written eg. 42+8 = 50, will be treated as malpractice.

- 5 a. Define the following with respect to transportation problem:
- Basic feasible solution
  - Optimal solution
  - Degenerate basic feasible solution.
- (06 Marks)
- b. For the following Transportation Problem a solution is given check it for optimality. If not, modify it to obtain a better solution (next best).

	D <sub>1</sub>	D <sub>2</sub>	D <sub>3</sub>	D <sub>4</sub>	Available units
S <sub>1</sub>	6	1	9 <sub>(50)</sub>	3 <sub>(20)</sub>	70
S <sub>2</sub>	11 <sub>(55)</sub>	5	2	8	55
S <sub>3</sub>	10 <sub>(30)</sub>	12 <sub>(35)</sub>	4	7 <sub>(25)</sub>	90
Demand units	85	35	50	45	

(10 Marks)

- 6 The captain of a cricket team has to allot five middle batting positions to 5 batsmen. The average runs scored by each batsman at these positions are as follows:

Batsman	Batting Position				
	I	II	III	IV	V
P	40	40	35	25	50
Q	42	30	16	25	27
R	50	48	40	60	50
S	20	19	20	18	25
T	58	60	59	55	53

- Find the assignment of batsman to positions which would give the maximum number of runs.
- If another batsman 'U' with the following average runs in batting position as given below:

Battery positions:	I	II	III	IV	V
Average runs scored:	45	52	38	50	49

is added to the team, should he be included to play in the team? If so, who will be replaced by him?

(16 Marks)

- 7 a. Define:
- Preceding activity
  - Dummy activity
  - Network
  - Slack.
- (06 Marks)
- b. Tasks A, B, C, ..., H, I constitute a project. The precedence relationships are A < D, A < E, B < F, D < F, C < G, C < H, F < I, G < I.

Task:	A	B	C	D	E	F	G	H	I
Time, days :	8	10	8	10	16	17	18	14	9

- Draw the network
- Identify the critical path and duration.

(10 Marks)

- 8 a. Discuss the operating characteristics of a queueing system. (06 Marks)
- b. A typist at an office of a company receives on the average 20 letters/day for typing. The typist works 8 hours a day and it takes on the average 20 minutes to type a letter. The cost of a letter waiting to be mailed is 80 paise/hr and the cost of the equipment plus salary of the typist is Rs.45 per day.
- What is the typists utilization rate?
  - What is the average number of letters waiting to be typed?
  - What is the average waiting time needed to have a letter typed?
  - What is the total daily cost of waiting letters to be mailed.

(10 Marks)

- 9 a. Define:
- Strategy
  - 2 person zero sum game
  - Pay off matrix.
- b. Solve the following game by using principle of dominance:

(06 Marks)

		Player B					
		I	II	III	IV	V	VI
Player A	1	4	2	0	2	1	1
	2	4	3	1	3	2	2
	3	4	3	7	-5	1	2
	4	4	3	4	-1	2	2
	5	4	3	3	-2	2	2

(10 Marks)

- 10 a. Discuss any three priority rules of processing n jobs through one machine. (06 Marks)
- b. Four jobs 1, 2, 3 and 4 are to be processed on each of the four machines. A, B, C and D in the order ABCD. The processing times in minutes are given in the table below. Find, for no passing the minimum elapsed time and idle time for each machine.

		Machines			
		A	B	C	D
Jobs	1	58	14	14	48
	2	30	10	18	32
	3	28	12	16	44
	4	64	16	12	42

(10 Marks)

\* \* \* \* \*

# CBCS SCHEME

USN

--	--	--	--	--	--	--	--	--	--

15ME82

## Eighth Semester B.E. Degree Examination, July/August 2021 Additive Manufacturing

Time: 3 hrs.

Max. Marks: 80

**Note: Answer any FIVE full questions.**

- 1 a. Explain the need for Additive Manufacturing. (06 Marks)  
b. Explain with a neat sketch, the working principle, merits and demerits and applications of Discrete Particle Additive Manufacturing System. (10 Marks)
- 2 a. Distinguish between Additive Manufacturing and CNC Machining. (06 Marks)  
b. Explain with a neat sketch, the working principle, advantages, disadvantages and applications of Solid Sheet additive manufacturing system. (10 Marks)
- 3 a. Explain with neat sketches, the salient features of DC motors with field coil. (10 Marks)  
b. Explain with neat diagrams, the salient features and characteristics of Thyristor and Triac. (06 Marks)
- 4 a. Explain with neat sketches, the working principle of following hydraulic motors :  
i) Vane motor ii) Gear motor. (08 Marks)  
b. Write a note on the following :  
i) Shape memory alloys ii) Piezo electric actuators. (08 Marks)
- 5 a. Explain the main steps in powder metallurgy. (08 Marks)  
b. Explain with neat sketches the following :  
i) Tape casting ii) Slip casting. (08 Marks)
- 6 a. Explain with a neat sketch, the working principle of polymer processing by wet spinning. What are its advantages and disadvantages? (08 Marks)  
b. Explain in detail Liquid Phase Sintering. (08 Marks)
- 7 a. Explain with neat sketches, Top-down and Bottom-up approaches pertaining to Nanotechnology. (06 Marks)  
b. Explain with a neat sketch, the working principle, uses and applications of Scanning Electron Microscopy (SEM). (10 Marks)
- 8 a. Explain with a neat sketch, production of Ultrafine powders by Mechanical grinding. (06 Marks)  
b. Explain with a neat sketch, the working principle, merits, demerits and application of Atomic Force Microscopy (AFM). (10 Marks)
- 9 a. Explain the various Automation principles and Strategies. (10 Marks)  
b. Distinguish between NC, CNC and DNC systems, with neat block diagrams. (06 Marks)

Important Note : 1. On completing your answers, compulsorily draw diagonal cross lines on the remaining blank pages.  
2. Any revealing of identification, appeal to evaluator and/or equations written eg. 42+8 = 50, will be treated as malpractice.

- 10 a. Explain with a block diagram the various levels of Automation. (08 Marks)
- b. Write an NC part program for the part shown in Fig. Q10(b) depicting drilling operation. Use the following data :  
 Spindle speed = 1000 rpm.  
 Feed = 0.05mm/rev.  
 Starting point of tool is at  $X = 0$  ,  $Y = -50\text{mm}$  ;  $Z = 10\text{mm}$ .  
 Diameter of drill = 7mm.  
 Consider absolute positioning system. (08 Marks)

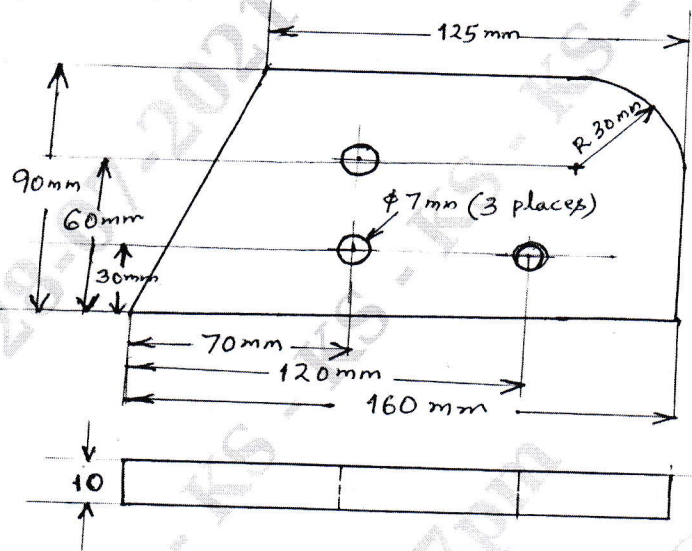

Fig. Q10(b) : A simple part depicting drilling operation

\*\*\*\*\*

# CBCS SCHEME

USN

--	--	--	--	--	--	--	--	--	--

15ME835

**Eighth Semester B.E. Degree Examination, July/August 2021**

## **Product Life Cycle Management**

Time: 3 hrs.

Max. Marks: 80

*Note: Answer any FIVE full questions.*

- 1 a. Define PLM? Explain the different stages of PLM. (08 Marks)  
b. Discuss and explain briefly the components of PLM. (08 Marks)
- 2 a. Discuss and explain the steps involved in product life cycle model with a neat sketch. (06 Marks)  
b. Summarize the five step process in implementing the PLM strategy. (10 Marks)
- 3 a. Define Engineering Design? Explain briefly the steps involved in Engineering Design. (08 Marks)  
b. Define Product Recycling? Discuss the various benefits of product recycling. (08 Marks)
- 4 a. Discuss and explain briefly the concepts involved in organization and decomposition in product design by considering a suitable example. (08 Marks)  
b. Discuss and explain briefly the different guidelines to be followed during design for manufacturing and assembly. (08 Marks)
- 5 a. Explain the benefits of New Product development. (06 Marks)  
b. Summarize the steps involved in estimating the market opportunities for a new product. (10 Marks)
- 6 a. Discuss the steps involved in launching of a New Product. (10 Marks)  
b. Explain briefly the need and benefits of product redesign. (06 Marks)
- 7 a. Explain briefly the elements of Technology forecasting. (06 Marks)  
b. Define Technology forecasting. Explain briefly the methods of technology forecasting. (10 Marks)
- 8 a. Discuss and explain briefly the importance of Relevance tree and mission flow diagram used in technology forecasting. (08 Marks)  
b. Explain briefly the methodologies and tools involved in product innovation process. (08 Marks)
- 9 a. Summarize the tools involved in virtual product development. (08 Marks)  
b. Illustrate with an example the Generic Product Structure. (08 Marks)
- 10 a. Define product data technology. Explain briefly the different categories of product data technology. (06 Marks)  
b. Define Data Model. Explain briefly the different types of data models used in product life cycle management. (10 Marks)

Important Note : 1. On completing your answers, compulsorily draw diagonal cross lines on the remaining blank pages.  
2. Any revealing of identification, appeal to evaluator and /or equations written eg, 42+8 = 50, will be treated as malpractice.