

CBCS SCHEME

USN

--	--	--	--	--	--	--	--	--	--

15ME72

Seventh Semester B.E. Degree Examination, Jan./Feb.2021

Fluid Power Systems

Time: 3 hrs.

Max. Marks: 80

Note: Answer any FIVE full questions, choosing ONE full question from each module.

Module-1

- 1 a. Explain the components required in a fluid power system with a diagram and list the advantages and applications. (08 Marks)
- b. State Pascal's law. Explain its application with a diagram. (08 Marks)

OR

- 2 a. How are hydraulic seats classified? Explain them in brief. (08 Marks)
- b. What are the types of contaminants? Explain the sources of contamination. (08 Marks)

Module-2

- 3 a. A pump has a displacement volume of 100 cm^3 . It delivers $1.5 \times 10^{-3} \text{ m}^3/\text{sec}$ at 1000 rpm and 70 bars. If the prime mover input torque is 120 N-m,
- (i) What is the overall efficiency of the pump? (08 Marks)
- (ii) What is the theoretical torque required to operate the pump? (08 Marks)
- b. What are the types of Accumulator? Explain with a neat circuit diagram the use of accumulator as a leakage compensator. (08 Marks)

OR

- 4 a. Explain the operation of a Vane motor with a neat sketch. (08 Marks)
- b. Explain single and double acting hydraulic cylinders with diagrams and their graphic symbols. (08 Marks)

Module-3

- 5 a. Explain shuttle valve and check valve with diagrams. (08 Marks)
- b. Explain the operation of pressure compensated flow control valve with a neat sketch. (08 Marks)

OR

- 6 a. Explain with a circuit diagram the working of double pump hydraulic system. (08 Marks)
- b. Explain with circuit diagrams the working of meter-in and meter-out for controlling of a speed of hydraulic cylinder. (08 Marks)

Module-4

- 7 a. What are the advantages, limitations and applications of pneumatic system? (08 Marks)
- b. Explain with a neat diagram the working of a pneumatic cylinder cushioning. (08 Marks)

OR

- 8 a. Explain the working of Quick-exhaust valve with a diagram and an application circuit. (08 Marks)
- b. Explain the constructional features of a time-delay valve with a diagram and graphic symbol. (08 Marks)

Important Note : 1. On completing your answers, compulsorily draw diagonal cross lines on the remaining blank pages.
2. Any revealing of identification, appeal to evaluator and/or equations written eg. 42+8 = 50, will be treated as malpractice.

Module-5

- 9 a. Explain the functions of 'OR' and 'AND' gates with shuttle and twin pressure valves respectively. (08 Marks)
- b. Explain with a neat circuit diagram in controlling of extension of a double acting cylinder using OR and AND logic gates. (08 Marks)

OR

- 10 a. Explain with neat circuit diagram signal elimination by reversing valves. (08 Marks)
- b. Explain the control circuitry for single and double acting cylinders using limit switches. (08 Marks)

CBCS SCHEME

USN

1	K	S	I	S	M	E	1	0	7
---	---	---	---	---	---	---	---	---	---

15ME73

Seventh Semester B.E. Degree Examination, Jan./Feb.2021 Control Engineering

Time: 3 hrs.

Max. Marks: 80

Note: Answer any FIVE full questions, choosing ONE full question from each module.

Module-1

- 1 a. What are the ideal requirements of a control system? Explain. (08 Marks)
- b. Explain the following controllers with the help of block diagrams and response curves: (08 Marks)
 - (i) Proportional plus integral.
 - (ii) Proportional plus integral plus derivative.

OR

- 2 a. How control systems are broadly classified? Explain with the help of block diagrams and examples. (08 Marks)
- b. Compare and contrast proportional, integral and differential controllers. (08 Marks)

Module-2

- 3 a. For the physical system shown in Fig. Q3 (a), draw the Free Body diagram and write the system equations in time domain and S domain. (10 Marks)

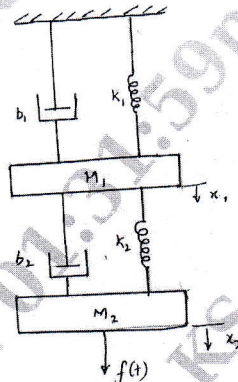

Fig. Q3 (a)

- b. With usual notations, obtain the transfer function of a field controlled D.C. motor. (06 Marks)

OR

- 4 a. Obtain the control ratio C/R for the block diagram shown in Fig. Q4.(a). (08 Marks)

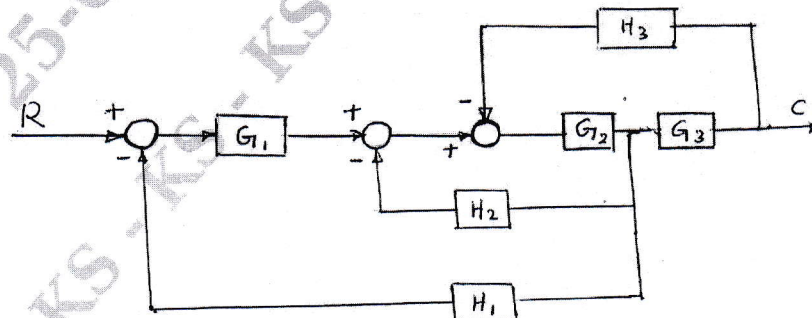

Fig. Q4 (a)

Important Note : 1. On completing your answers, compulsorily draw diagonal cross lines on the remaining blank pages.
2. Any revealing of identification, appeal to evaluator and /or equations written eg, 42+8 = 50, will be treated as malpractice.

- b. Find the transfer for the signal flow graph shown in Fig. Q4 (b) by using Mason's gain formula. (08 Marks)

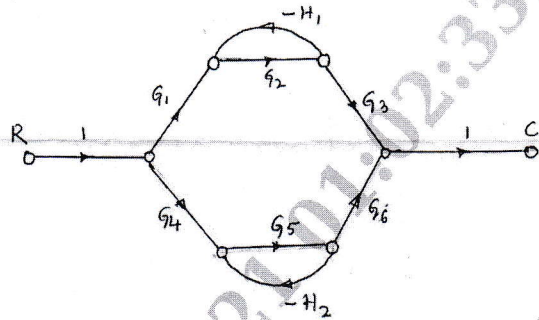

Fig. Q4 (b)

Module-3

- 5 a. With the help of a time response curve of a second order system, explain the following:
 (i) Delay time (ii) Rise time (iii) Peak time (iv) Settling time
 (v) Maximum over shoot (08 Marks)
- b. The open loop transfer function of a unity feedback system is $G(s) = \frac{4}{s(s+1)}$. Determine natural frequency, damped natural frequency, rise time, peak time, peak overshoot and settling time. (08 Marks)

OR

- 6 Sketch the root locus plot for the given system, $GH = \frac{K}{s(s+4)(s+2+2j)(s+2-2j)}$ and determine the range of K for which the system remains stable. (16 Marks)

Module-4

- 7 a. State and explain Nyquist stability criteria. (04 Marks)
 b. Draw the complete Nyquist plot for the system whose open loop transfer function is given by, $GH = \frac{K}{s(1+0.1s)(1+0.5s)}$. Determine the range 'K' for which the system is stable. (12 Marks)

OR

- 8 The open loop transfer function of a unity feedback control system is:
 $G(s) = \frac{90(1+0.5s)}{(1+0.1s)(1+2s)(1+0.02s)}$.
 Draw Bode plot and determine phase margin and gain margin. (16 Marks)

Module-5

- 9 a. What are the types of compensation? Explain with the help of simple block diagrams. (08 Marks)
 b. What are the characteristics of lead compensator? Explain a simple lead compensator with simple diagram. (08 Marks)

OR

- 10 a. Define controllability. What is Kalman's test for controllability and observability? (06 Marks)
 b. Using Kalman's test, determine the controllability of the following system:

$$\begin{bmatrix} \dot{x}_1 \\ \dot{x}_2 \\ \dot{x}_3 \end{bmatrix} = \begin{bmatrix} -2 & 1 & 2 \\ 4 & 0 & 3 \\ 1 & -1 & 0 \end{bmatrix} \begin{bmatrix} x_1 \\ x_2 \\ x_3 \end{bmatrix} + \begin{bmatrix} 0 & 4 \\ -5 & 0 \\ 0 & 0 \end{bmatrix} \begin{bmatrix} u_1 \\ u_2 \end{bmatrix}$$

(10 Marks)

CBCS SCHEME

USN

--	--	--	--	--	--	--	--	--	--

15ME753

Seventh Semester B.E. Degree Examination, Jan./Feb. 2021 Mechatronics

Time: 3 hrs.

Max. Marks: 80

Note: Answer any FIVE full questions, choosing ONE full question from each module.

Module-1

- 1 a. Define mechatronics. Explain the difference between conventional approach and mechatronic approach. (08 Marks)
b. List the objectives, advantages and disadvantages of mechatronics. (08 Marks)

OR

- 2 a. Explain the principle of capacitive proximity sensor. (08 Marks)
b. What is "Hall Effect"? Explain with a neat simple sketch the principle of Hall effect. (08 Marks)

Module-2

- 3 a. Explain with a block diagram the organization of microprocessor. Explain in brief the function of each element in it. (10 Marks)
b. What is a microcontroller? Explain the classification of microcontrollers. (06 Marks)

OR

- 4 a. Define the following terms: (06 Marks)
(i) Data width (ii) RAM (iii) ROM (iv) Read cycle (v) Write cycle (vi) Interrupts
b. What are buses? Explain the different types of buses. (10 Marks)

Module-3

- 5 a. Explain briefly basic structure of Ladder logic diagram. (08 Marks)
b. Explain various requirements for selecting a Programmable Logic Controller. (08 Marks)

OR

- 6 a. Define PLC. Explain with a neat diagram working of a PLC. (08 Marks)
b. Explain briefly functional requirement of robot. (08 Marks)

Module-4

- 7 a. Explain the mechanical actuation system with examples. (03 Marks)
b. What is the principle of a solenoid? What are the two basic types of Solenoid? Explain the working of any one of them. (10 Marks)
c. What are the types of motion any rigid body? (03 Marks)

OR

- 8 a. Explain with circuit diagram and characteristics of curves, shunt wound d.c. motor. (06 Marks)
b. Explain with a neat diagram the working of a permanent magnet stepper motor to achieve step rotation. (10 Marks)

Module-5

- 9 a. With neat sketch, explain the construction of the hydraulic system. (10 Marks)
b. Explain with a neat diagram the working of a
(i) single acting cylinder (ii) double acting cylinder. (06 Marks)

OR

- 10 a. Explain with neat diagram the construction and working of an external gear motor. (08 Marks)
b. With neat sketch, explain pressure relief valve. (08 Marks)

* * * * *

Important Note : 1. On completing your answers, compulsorily draw diagonal cross lines on the remaining blank pages.
2. Any revealing of identification, appeal to evaluator and /or equations written eg, 42+8 = 50, will be treated as malpractice.