

## SWARM ROBOTICS FOR AGRICULTURE

Ravi Nandan<sup>1</sup>, Lokesh S<sup>2</sup>, Nikita Balappa Narasannavar<sup>3</sup>, Pratyusha S A<sup>4</sup>, Sampath Kumar S<sup>5</sup>

<sup>1 2 3 4</sup>Department of ECE, K S Institute of Technology, Bengaluru, India

<sup>5</sup>Assistant Professor, Dept. of ECE, K S Institute of Technology, Bengaluru, India

\*\*\*

**Abstract** - The swarm behavior of the social insects led to development of swarm robot technology. There are different algorithms to perform successful navigation but most commonly used algorithm is Practical Swarm Optimization (PSO) algorithms. The main issue in swarm robotics is to establish communication between them. This paper demonstrates how robot switch state between centralization and decentralization mode using implicit communication. With the help of IR sensors (1 meter range) and RF Transceivers (2.4GHz) obstacles can be avoided by the robots. If the main robot couldn't detect any obstacle while performing the task, then robot continues to follow the main robot as per centralization behavior mode. Suppose if obstacle is in between the two robots then it can be avoided with the help of IR sensor's information. The prototype of robots consists of Arduino Uno ATMEGA328P which is used as the control unit for both main robot and follower robot with a transceiver pair of NRF24L01 (2.4 GHz) to establish communication between them.

**Key Words:** Arduino Uno ATMEGA328P, transceiver pair NRF24L01, Swarm

### 1. INTRODUCTION

Agriculture is a backbone of Indian economy. In India about 64% of the total population is dependent on agriculture. It faces two main problems; the first is to meet the ever increasing demand of food and second is uneven development of agriculture and changing pattern of agriculture land use. In earlier days, before using technology in agriculture field it was a difficult task for various agricultural operations and farmers could not meet the required productivity of crops. So in this paper we represent a system (model) which helps to reduce burden of farmers.

To coordinate large number of multi robots swarm robotics approach is employed. Field of artificial swarm intelligence is one of the emerging approaches. Swarm intelligence focuses of simple physical on collective behavior exhibited by natural grouping systems such as ant, bees, birds, fishes, etc. Some of agricultural applications of swarm robots are sowing seeds, harvesting, and storing grains in the warehouse. To reduce the work load of farmers and to increase their productivity swarm robotics has played a important role in the field of agriculture.

Swarm robotics concentrates on communication an interaction between the robots. An individual robot takes much more time for doing a particular work compared to swarm system and performs limited work in a given time period and has limited capability. Swarm robotics will reduce the cost, eliminate the major problem of unavailability of work-force, reduce waste of land drastically, increase productivity, and constantly monitor the crops throughout its growth period.

### 2. LITERATURE SURVEY

Karthik Narayanan, et al. [1] proposed a coding scheme designed for data compression in multi-robot systems. Huffman encoding for lossless data compression was used and here time and power optimization is obtained. The proposed method is implemented and tested on the Intel Edison platform with custom robot chassis. In Huffman encoding a minor change in any bit of the encoded string would break the whole message.

Dario Albani, et al. [2] proposed a roadmap to bring swarm robotics to the field within the domain of weed control problems. This paper presents automatic detection and identification of weeds. A swarm of UAVs which will be recruited to monitor those areas in the field that have been identified as potentially containing weed patches, while weed less areas are quickly abandoned by the swarm. But this concept has limited coverage area.

Syed IrfanAli Meerza, et al. [3] proposed a method to direct the mobile robot toward a target and navigation through the environment without any prior knowledge about the environment. This paper introduces particle swarm optimization (PSO) with dynamic obstacle avoidance technique for robot path planning. Our proposed systems are simulated and tested in Processing IDE, for different environments. Computational simplicity is the feature of this system and it also requires less memory.

Jhang Jian Ju, et al. [4] proposed self-assembly distributed control algorithm which aims to improve self-assembly efficiency of the swarm robot by lowering ineffectiveness of random navigational movement during self-assembly process and enabling dynamic local navigation of random movement according to the distance of seed robot and docking robot. In addition, this paper also studied and explored time efficiency of line-shape, arrow-shape, T-shape and star-shape morphology. This technique improves the efficiency of self-assembly.

Harish Verlekar, et al. [5] proposed a method based on the chain formation behavior of ants and division of labor in bees is emulated. Swarm robots are designed to emulate the ants, and form chains while foraging and the division of labor is used for preventing wastage of energy. For localization and navigation a computer vision based algorithm is used which is coupled with magnetometer sensor readings. Utilizing swarm robots approach we get Parallelism, Robustness and Scalability.

Dunwei Gong, et al. [6] introduced particle swarm optimization (PSO) with dynamic obstacle avoidance technique for robot path planning. Our proposed systems are simulated and tested in Processing IDE, for different environments. This paper proposes a PSO with dynamic collision avoidance technique for a multi-robot system. PSO is chosen due to its fast convergence capability and computational simplicity.

Jong-Hyun Lee1, et al. [7] proposed a method which analyzes a nature enthused supportive method to reduce the operating costs of the foraging swarm robots through simulation experiments. The method employs a behavioral model of honey bee swarm to improve the energy efficiency in collecting crops or minerals. The division of roles makes the complex social of honey bee operate efficiently. Foraging swarm robots consists of a crowd of robots to gather target objects based on a behavioral model. The robot mounts an infra-red sensor to look for the target objects (i.e., foods) or to avoid obstacles, and has GPS to figure out a location of the storehouse.

Senthil Kumar, et al [8] proposed a model to establish a communication among a group of robots using ZigBee and to communicate among the group of robots using ZigBee which perform a task allocated to each slave robot. Slave robots will send the status to master robot and master robot will give command to those robots. Zigbee module we will use to established communication. We make use of ZigBee module for performing different tasks and allocating work between them.

### 3. BLOCK DIAGRAM

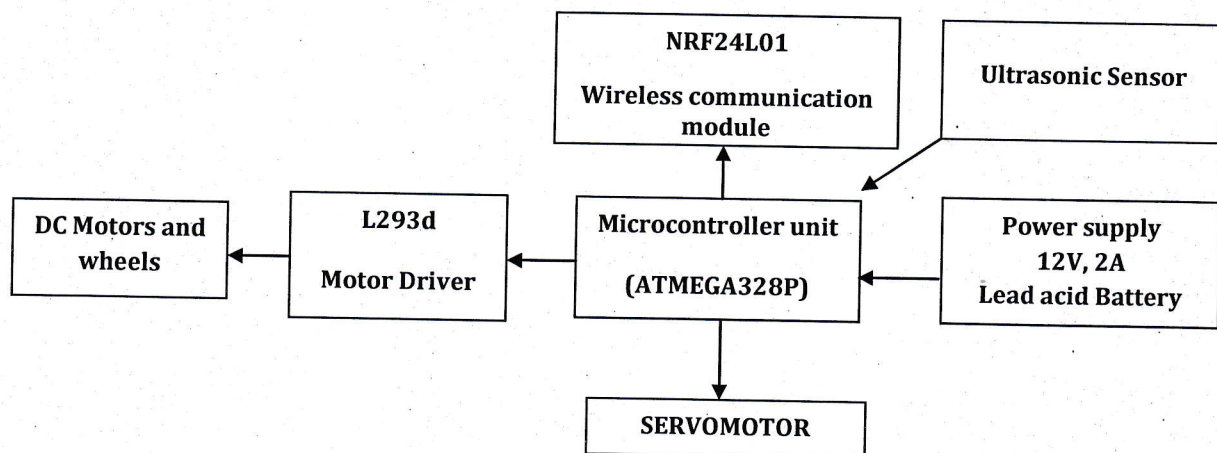

#### 4. METHODOLOGY

The term swarm robotics refers to coordinate large number of multirobots with simple physical robots. This behavior tells how robot interacts between the robots and with the environment. The field of artificial swarm intelligence, biological studies of insects, ants and other fields in nature are some of approaches, where swarm behavior occurs. The project demonstrates the advance level of swarm robotics where two robots will talk to each other and would tell the other robot about the obstacle's, seed sowing, ploughing and manuring. Initially two robots should be placed in a field then those two will start to operate in a coordination by communicating each other, both robots will start for ploughing, seed sowing and manuring operations, for ploughing an extra tool will be provided at the back of the robot chassis and it will be controlled by a DC motor. In corresponding seed sowing operation also be carried by the help of servo motor, all these information will be keep on communicating between the robots using NRF24L01 Radio module. Suppose the first robot finds the obstacle's on his way it will tell another robot that there is obstacle ahead please take a turn of, the turn will be 90 degree. This is just like self driving car where two cars are communicating with other to avoid any accidents and smart enough to alert the other cars. This action can be easily implemented for agriculture purpose in order increase the production and minimize the time complexity.

##### Description of hardware requirements:

###### 1. Microcontroller (ATMEGA328P):

High performance, low power CMOS 8bit microcontroller.

- Operating voltage :( 1.8-5.5V).
- Temperature range:(-40 to 85) degree Celsius.
- Speed :( 0-20MHz).

ATmega328P in 28 pin narrow dual in-line package (DIP-28N).It has a modified Harvard architecture 8-bit RISC processor core. Throughput of 1MIPS per MHz can be achieved by ATMEGA328P which allows system design to optimize power consumption versus processing speed.

###### 2. NRF24L01:

Single chip radio transceiver for the worldwide 2.4-2.5GHz ISM band.

Parameter of transceiver.

- Fully integrated frequency synthesizer.
- Power amplifier.
- Crystal oscillator.
- Demodulator and modulator and enhanced shock burst protocol engine.

Power supply range is 1.9-3.6v. Output power, frequency channels and protocols setup as compared to others are easily programmable through a SPI interface.NRF24L01 consumes less current at a rate of 12.3mA in RX mode. Built-in power down and stand by modes makes power saving easily reliable.

###### 3. Servo motor:

It is a motor that controls the operations of angular position, acceleration and velocity. It is a High response, High precision positioning system. It provides accurate rotational angle and speed control. It is close loop system where it uses positive feedback system to control motion and final position of the shaft. Here, the device is controlled by feedback signal generated by comparing output signal and reference input signal. Electrical pulse decides the position of servo motor.

###### 4. DC motor:

It is a device that converts direct current electrical energy into mechanical energy. The speed of dc motor depends on the gear ratio and can be controlled over a wide range using either or variable supply voltage or by changing the strength of current in its field windings. Dc motor can be use that voltage lower than rated voltage. It has operating speed of 1000 to 5000rpm, 60-75% efficiency rate, high starting torque and low no-load speeds.

###### 5. Ultrasonic Sensor:

It measures distance by using ultrasonic waves. The sensor head emits an ultrasonic wave and receives the wave reflected back from the target. Ultrasonic Sensors measure the distance to the target by measuring the time between the emission and

reception. An optical sensor has a transmitter and receiver, whereas an ultrasonic sensor uses a single ultrasonic element for both emission and reception. In a reflective model ultrasonic sensor, a single oscillator emits and receives ultrasonic waves alternately. This enables miniaturization of the sensor head.

Features are:

1. Transparent object detectable
2. Resistant to mist and dirt
3. Complex shaped objects detectable

## 5. FLOWCHART

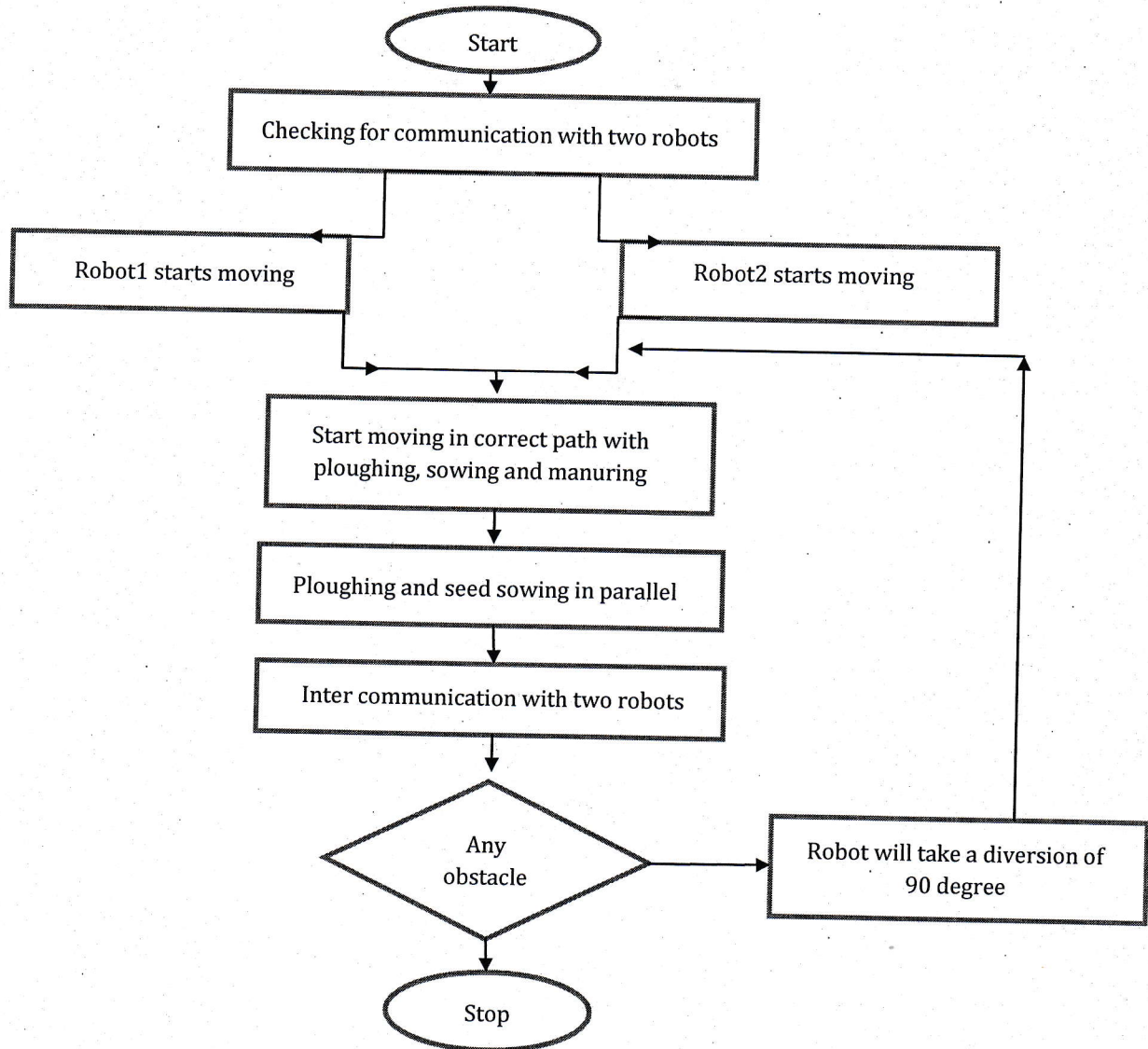

## 6. CONCLUSION

In our proposed study, we are developing two robots which can intercommunicate with each other and fulfill the operations of ploughing, seeding and manuring. A PSO based algorithm is used that has collision avoidance which we proposed with the help of ultrasonic sensors which has a range of upto 100cm and has collision avoidance capability for static objects and dynamic objects. In future we are willing to test our system in real world environment. The aim of our team is to incorporate efficient technology in the field of agriculture and reduce the workload of farmers.

**REFERENCES**

- [1] Karthik Narayanan, Vinayak Honkote, Dibyendu Ghosh, Swamy Baldev (13 May 2019) "Energy Efficient Communication with Lossless Data Encoding for Swarm Robot Coordination" 2380-6923/19/\$31.00 ©2019 IEEE DOI 10.1109/VLSID.2019.00118
- [2] Dario Albani, Joris Ijsselmuiden, Ramon Haken, Vito Trianni(2017) "Monitoring and mapping with robot swarms for agricultural applications" 978-1-5386-2939-0/17/\$31.00 c 2017 IEEE
- [3] Syed IrfanAli Meerza; MoinulIslam;Md. MohiuddinUzzal (23 May 2019) "Optimal Path Planning Algorithm for Swarm of Robots Using Particle Swarm Optimization Technique" 978-1-4673-7523-8/15/\$31.00 ©2015 IEEE
- [4] Jhang Jian Ju, Ge YunJian(2017) "A enhanced self-assembly morphology distributed control algorithm of swarm robots" 978-1-5386-1306-1/17/\$31.00 ©2017 IEEE
- [5] Harish Verlekar, Kashyap Joshi (2017) "Ant & Bee Inspired foraging Swarm Robots using Computer Vision" 978-1-5386-2361-9/17/\$31.00 ©2017 IEEE
- [6] Li Lu, Dunwei Gong (2008) "Robot Path Planning in Unknown Environments Using Particle Swarm Optimization" 978-0-7695-3304-9/08 \$25.00 © 2008 IEEE DOI 10.1109/ICNC.2008.923
- [7] Jong-Hyun Lee1, Chang Wook Ahn1, and Jinung An2 (2013) "A Honey Bee Swarm-Inspired Cooperation Algorithm for Foraging Swarm Robots: An Empirical Analysis" IEEE/ASME International Conference on Advanced Intelligent Mechatronics (AIM) Wollongong, Australia, July 9-12, 2013
- [8] 1J.Senthil Kumar Assistant Professor 2E.Sweetline Sylvia Student 3C.Srijayasri Student4G.Sharmila Student "Task Coordination And Control Between Swarm Of Robots For Assisting Farmers" International Journal of Advanced Research in Electronics and Communication Engineering (IJARECE) Volume 6, Issue 3, March 2017